

PORTABLE TYPE ULTRASONIC FLOWMETER (PORTAFLOW-C)

DATA SHEET

FSC, FLD/FSD

PORTAFLOW-C is a portable type ultrasonic flowmeter utilizing transit time difference for measuring flow rates in pipes from the outside.

It is a compact and light-weight instrument incorporating the latest electronics and digital signal processing technologies, realizing high performance and easy operation.

FEATURES

1. **Compact and light-weight**
The adoption of the latest electronics and digital signal processing technologies has reduced the size and weight of the flow transmitter by 30% and 40%, respectively, in comparison with traditional model.
2. **Battery operation**
This flowmeter is designed for 12 hours of continuous operation with its own built-in battery which is rechargeable in 3 hours with the supplied power adapter.
3. **Full variety of detectors**
The flowmeter can be used with various types of detectors applicable for small to large diameter pipe ($\phi 13$ to $\phi 6000\text{mm}$) and low to high temperature (-40 to $+200^\circ\text{C}$).
4. **High accuracy and high-speed response**
The flowmeter is designed for high accuracy ($\pm 1.0\%$). Response time is within 1 second.
5. **Improvement in anti-bubble characteristic**
Anti-bubble characteristic is greatly improved by digital signal processing.
6. **Excellent performance and easy operation**
Large type graphic LCD that is bright but easy-to-see and minimum number of function keys are used for page selection, allowing easy setting.
The flowmeter is water-proof and can be used in a place where it is exposed to rain.
7. **Built-in SD memory card**
With standard capacity (256MB), data can be saved for a long time (available up to 8GB).
8. **Serial communication**
Use of a USB port allows you to connect a personal computer easily.
9. **Heat quantity measurement**
Heat quantity can be measured by temperature input, making energy management easy for cooling and heating.
10. **Graphic printer connection (option)**
Easy recording with the Integral type printer.
11. **Flow velocity profile measurement (option)**
Flow status can be observed in real time.
12. **Thickness measurement (option)**
Use of an optional thickness gauge probe enables measuring thickness of pipes.



Flow transmitter (FSC)



Detector, etc. (FLD)

SPECIFICATIONS

Measuring objects

Measurement fluid:

Uniform liquid in which ultrasonic waves can propagate.

Turbidity of fluid: 10000 mg/L or less

State of fluid: Well-developed turbulent or laminar flow in a filled pipe.

Fluid temperature: -40 to $+200^\circ\text{C}$

Measuring range: $0 \dots \pm 0.3$ to $\pm 32\text{m/s}$

Piping conditions

Applicable piping material:

Select from carbon steel, stainless steel, cast iron, PVC, FRP, copper, aluminum, acrylic or material of known sound velocity.

Pipe size:

Flow rate measurement

$\phi 13$ to $\phi 6000\text{mm}$

Flow velocity profile measurement

$\phi 40$ to $\phi 1000\text{mm}$

Lining material:

Select from no lining, tar epoxy, mortar, rubber, Teflon, pyrex glass or material of known sound velocity.

Note) There is no gap between the lining and the pipe.

Straight pipe length:

10D or more for up stream and 5D or more for down stream (D: internal pipe diameter)
 Refer to Japan Electric Measuring Instruments Manufactures' Association's standard JEMIS-032 for details.

Performance specifications

Accuracy rating:

Piping diameter (inner diameter)	Flow velocity range	Accuracy
φ13 to φ25mm	2 to 32m/s	±2.5% of rate
	0 to 2m/s	±0.05m/s
φ25 to φ50mm	2 to 32m/s	±1.5% of rate
	0 to 2m/s	±0.03m/s
φ50 to φ300mm	2 to 32m/s	±1.0% of rate
	0 to 2m/s	±0.02m/s
φ300 to φ6000mm	1 to 32m/s	±1.0% of rate
	0 to 1m/s	±0.01m/s

Note) Reference conditions are based on JEMIS-032.

Flow transmitter (Type: FSC)

Power supply: Built-in battery or power adapter
 Built-in battery: Special type lithium button battery (5000mAh)
 Continuous operation time, about 12 hours (without printer, back light OFF)
 Recharging time, about 3 hours (power adapter used)
 Power adapter: Special type power adapter 90V to 264V AC (50/60Hz)
 Power Consumption; Approx. 3W

LCD: Semi-transmissive color graphic display 240 × 320 dot (with back light)
 Measurement value (instantaneous flow rate, integrated flow rate) and various settings are displayed.
 Visibility is excellent even outdoors in direct sunlight.

LED display: DC IN (green), CHARGE (red)
 Status display when using AC power adapter.
 DC IN (green): Power supply status
 CHARGE (red): Battery charging under-way

Operating unit: keypad 11 points (ON, OFF, ENT, ESC, MENU, △, ▽, ◀, ▶, LIGHT, PRINT)
 Various settings are made.

Power failure backup: Measurement value is backed up by nonvolatile memory.
 Clock backup with lithium battery (effective term, 10 years or more)

Response time: 1 second

Analog output signals: 4 to 20mA DC, one point (load resistance, 600Ω or less)
 Instantaneous velocity, instantaneous flow rate or heat quantity is output after scaling.

Analog input signal:

4 to 20mA DC, one point (input resistance, 200Ω or less)
 4 to 20mA DC, one point (input resistance, 200Ω or less) or 1 to 5V DC, one point
 Used to input temperature for heat quantity measurement, etc.

Total 2 points

SD memory card: Standard 256MB, available up to 8GB
 Used for data logger function and recording screen data.

Serial communication:

USB port (device compatible):
 Mini B receptacles
 Connectable number of Mini B receptacles: 1 unit
 Transmission distance: 15m max.
 Transmission speed: 500kbps
 Data:
 Instantaneous velocity, instantaneous flow rate, total value, heat quantity value, error information, logger data, etc.

Printer (option): To be mounted on top of flow transmitter
 Thermal line dot printing

Ambient temperature:
 -10 to +55°C (Without printer)
 -10 to +45°C (With printer)

Ambient humidity: 90%RH or less
Type of enclosure: IP65 (Without printer)

Enclosure case: Plastic case
Outer dimensions: H210 × W120 × D65mm (Without printer)
 H320 × W120 × D65mm (With printer)

Weight: 1.0kg (Without printer)
 1.2kg (With printer)

Various functions

Display language: Select from Japanese, English, German, French or Spanish (switchable by key operation).

Clock display function: Time (year, month, day, hour, minute) display and setting available

Accuracy: Monthly variation about 2 minutes, except of time log when power is turned ON/OFF.

Instantaneous value display function:
 Instantaneous velocity, instantaneous flow rate display (The flow in reverse direction is displayed with minus "-.")
 Numeric value: 10 digits (decimal point is corresponding to 1 digit)
 Unit: Metric/English system selectable
 Metric system
 Velocity: m/s
 Flow rate: L/s, L/min, L/h, L/d, kL/d, ML/d, m³/s, m³/min, m³/h, m³/d, km³/d, Mm³/d, etc

Total value display function:

Display of forward or reverse total (reverse is displayed in minus)
 Numeric value: 10 digits (decimal point is corresponding to 1 digit)
 Unit: Metric/English system selectable
 Metric system
 Flow rate total: mL, L, m³, Km³, Mm³, etc

Consumed heat quantity display function:

Display of consumed heating medium
 Heat flow: MJ/h, GJ/h
 Total heat quantity: MJ, GJ

Computation function of consumed heat quantity:

This function calculates the heat quantity received and sent with liquid (water) in cooling and heating.

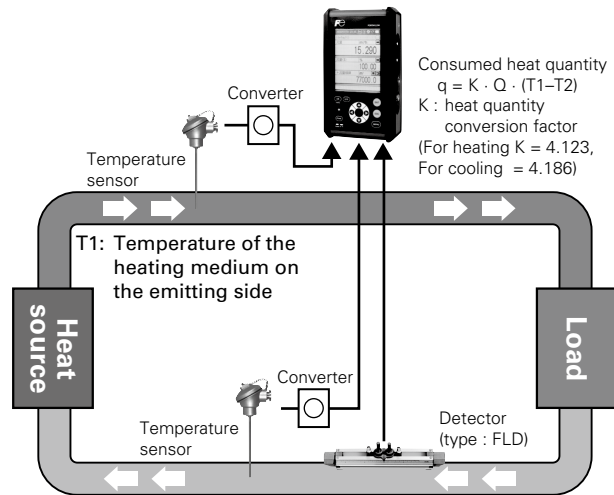

Consumed heat quantity
 $q = K \cdot Q \cdot (T1 - T2)$
 K : heat quantity conversion factor
 (For heating K = 4.123,
 For cooling = 4.186)

T2: Temperature of the heating medium of the receiving side
 Q: Flow rate of the heating medium

Temperature display function:

Fluid temperature is displayed by current input from temperature transmitter.
 Temperature: °C, K

Damping: 0 to 100sec (every 0.1sec) configurable for analog output and velocity/flow rate display

Low flow cut: Equivalent to 0 to 5m/s

Output setting function: Current output scaling, output type, burn-out setting and calibration available

Serial communication function: Instantaneous velocity, instantaneous flow rate, total value, heat flow, error information, received waveform, analog input, logger data, etc. can be downloaded in a personal computer.

Logger function: Instantaneous velocity, instantaneous flow rate, total value, heat flow, error information, received waveform, analog input can be saved in a SD memory card.

Waveform display function: Bi-directional received waveforms can be displayed.

Graph display function: Flow rate trend graph can be displayed.

Printing function (option): Hard copy output of a screen
 Periodic printing
 Logger data

Thickness measurement (option):

Pipe wall thickness can be measured from the outside using the special type thickness gauge (option).
 Measurement result can be reflected on the piping parameter.

Flow velocity profile measurement (option):

Flow velocity profile can be observed in real time using the special type detector (option).
 (Refer to page 6 for details.)

Detector (Type: FLD)

Type of detector:

Kind	Type	Internal pipe diameter (mm)	Fluid temperature
Small type	FLD12	φ50 to φ300	-40 to 100°C
Small diameter	FLD22	φ13 to φ100	-40 to 100°C
High temperature	FLD32	φ50 to φ400	-40 to 200°C
Middle type	FLD41	φ200 to φ1200	-40 to 80°C
Large type	FLD51	φ200 to φ6000	-40 to 80°C

Mounting method:

Mounting on outside of already constructed pipe

Sensor mounting method: V or Z method

Signal cable: Special type coaxial cable
 Standard 5m

Method for connection:

Flow transmitter side
 Special type connector
 Detector side
 Large/middle type: Screw terminal
 Others: BNC connector

Ambient temperature: -20 to +60°C

Ambient humidity: Large/middle type sensor:
 100%RH or less
 Others: 90%RH or less

Type of enclosure:

Large/middle type sensor: IP67
 Others: IP52

Material and mounting belt/wire:

Kind	Type	Sensor case	Mounting bracket	Mounting belt /wire
Small diameter	FLD22	Plastic	Aluminum alloy + Plastic	Plastic cloth belt
Small type	FLD12	Plastic	Aluminum alloy + Plastic	Plastic cloth belt
Middle type	FLD41	Plastic	--	Stainless wire
Large type	FLD51	Plastic	--	Stainless wire
High temperature	FLD32	SUS304	Aluminum alloy + SUS304	Stainless belt

Extension cable (option):

Extended when the length of the detector signal cable is not sufficient.
 Length: 10m, 50m

Thickness gauge (option):

Measuring range: 0.8 to 80mm
 Accuracy:
 Less than 20mm: ±0.1mm
 More than 20mm: ±0.5% of read
 Operating temperature: 0 to +50°C
 Ambient humidity: 90%RH or less

FLOW VELOCITY PROFILE DISPLAY FUNCTION (OPTION)

Flow velocity profile can be observed in real time using the dedicated detector from the outside. It is specifiable by the code symbol of flow transmitter.

APPLICATION

Pulse Doppler method is selected to observe flow velocity profile in real time, display the flow status in the pipe, and decide the appropriate measurement location. Also, it can be used for diagnosis of flow and laboratory test.

SPECIFICATIONS

Measuring fluid: Uniform liquid in which ultrasonic waves can propagate.

Turbidity of fluid: Axisymmetric flow in a filled pipe.

Fluid temperature:

-40 to +100°C (FSDP2)

-40 to +80°C (FSDP1, FSDP1)

Air bubble quantity:

0.02 to 15Vol% (Velocity is 1m/s)

Pipe size: Small type sensor : $\phi 40$ to $\phi 200$ mm

Middle type sensor : $\phi 100$ to $\phi 400$ mm

Large type sensor : $\phi 200$ to $\phi 1000$ mm

Measurement range:

0 to ± 0.3 : \pm Maximum Velocity (depending on the pipe diameter)

Maximum flow rate will hereinafter be described in detail.

Note) This function is to observe flow velocity profile, and it may be different from actual flow rate.

DETECTOR FOR FLOW VELOCITY PROFILE MEASUREMENT (TYPE: FSD)

Mounting method:

Mounting on outside of already constructed pipe

Ambient temperature: -20 to +80°C

Ambient humidity: 100% RH or less

Type of enclosure: IP67

Material: Sensor housing: PBT

Guide frame: Aluminum alloy

Mounting belt: Plastic cloth belt/stainless belt

Measurement principle

<Pulse Doppler method>

- Ultrasound pulses are transmitted into a liquid, and flow velocity profile is found and the flow rate is measured by using the characteristics that Doppler frequency of the echo from reflectors such as air bubbles and particles in the liquid changes according to flow velocity.

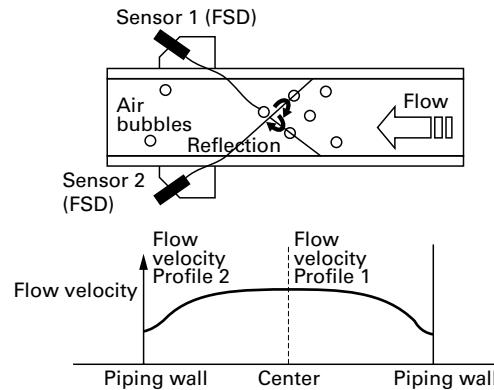

The above shows an example when using two sensors.

Block diagram

(1) Using one sensor

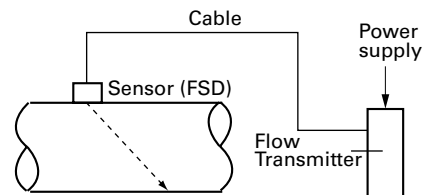

(2) Using two sensors

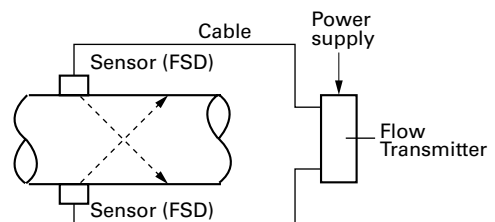

Maximum measurement range in pulse doppler method

When stainless steel is selected as pipe material, nominal wall thickness is Sch20s, and the fluid is water.

<Maximum measurable flow velocity>

<Maximum measurable flow rate>

Unit: m/s

Unit: m³/h

Caliber	FSDP2	FSDP1	FSDP0
40A	6.56		
50A	6.04		
65A	4.99		
80A	4.40		
90A	3.92		
100A	3.45	6.95	
125A		5.86	
150A		5.04	
200A		3.90	7.59
250A			6.26
300A			5.32
350A			4.82
400A			4.25
450A			3.80
500A			3.54
550A			3.14
600A			2.89
650A			2.69
700A			2.50
750A			2.34
800A			2.19
850A			2.07
900A			1.95
1000A			1.76

FSDP2	FSDP1	FSDP0
33.68		
48.5		
67.8		
81.8		
97.1		
110.2	222.0	
	279.2	
	343.2	
	462.8	887
		1,146
		1,404
		1,572
		1,831
		2,091
		2,393
		2,587
		2,850
		3,067
		3,325
		3,590
		3,839
		4,112
		4,357
		4,852

Loader software for PCs

Equipped as standard

- Works on PC/AT compatible machines.
- Operation on PC98-series machines (NEC) cannot be guaranteed.
- Operation on self-made PCs or shop-brand PCs cannot be guaranteed.
- Major functions: Performs various parameter setting/change of the main unit.

Instantaneous velocity, instantaneous flow rate, total value, error information, received waveform, analog input, logger data, etc. can be downloaded in a personal computer.

- O/S: Windows2000/XP
- Memory requirement: 128MB or more
- Disk unit: Windows2000/XP-compatible CD-ROM drive
- Hard disk drive capacity: Free space of 52MB or more

CODE SYMBOL

<Flow transmitter>

1 2 3 4 5 6 7 8								Description
F	S	C					1	<Specification> Standard
	S							<Converter> Basic system Basic system + Printer Basic system + Thickness gauge Basic system + Printer + Thickness gauge
			1					<Flow velocity profile measurement> None Provided (detector to measure flow velocity profile is separately required.)
			2					
			3					
			4					
				0				<Power adapter> AC power + power cord (125V AC) for Japanese and North American use AC power + power cord (250V AC) for European and Korean use AC power + power cord (250V AC) for Chinese use
				1				
					A			
						B		Modification No.
						C		
							1	

<Detector>

(for transit time)

1 2 3 4 5 6 7 8 9								
F	L	D						A
Description								
<Kind>								
1	2							
2	2							
3	2							
4	1							
5	1							
Small type (for $\phi 50$ to $\phi 300$ mm)								
Small diameter (for $\phi 13$ to $\phi 100$ mm)								
High-temperature (for $\phi 50$ to $\phi 400$ mm) Note								
Middle type (for $\phi 200$ to $\phi 1200$ mm)								
Large type (for $\phi 200$ to $\phi 6000$ mm)								
<Terminal mold>								
0								
1								
None								
Provided (Middle/Large type only)								
<Structure>								
Y								
General use								
1								
Modification No.								

Note)

Use the optional guide rail, if a pipe that does not allow ultrasonic waves to pass through easily, such as when an old pipe, cast iron pipe or a pipe with mortar lining is used, or the flow or liquid high in turbidity is measured. Employ the Z method for mounting.
Applicable diameter range: V method: $\phi 50$ to $\phi 250$
Z method: $\phi 150$ to $\phi 400$

(for flow velocity profile measurement)

1 2 3 4 5 6 7 8							
F	S	D		0	Y	1	
Description							
<Kind>							
P	2						
P	1						
P	0						
Small type ($\phi 40$ to $\phi 200$ mm)							
Middle type ($\phi 100$ to $\phi 400$ mm)							
Large type ($\phi 200$ to $\phi 1000$ mm)							
<Terminal mold>							
0							
None							
<Structure>							
Y							
General use							
1							
Modification No.							

SCOPE OF DELIVERY

<Flow transmitter>

Name of unit	Scope of delivery
1 Basic system	1) Conversion unit 2) Power adapter 3) Power connector conversion cord 4) Analog input/output cord (1.5m) 5) USB cable 6) Carrying case 7) Strap 8) SD card (256MB) 9) Special type signal cable (5m \times 2) 10) BNC adapter
2 Printer (option)	1) Printer unit 2) Printer rolled paper (1 roll)
3 Thickness gauge (option)	1) Thickness gauge (with cable) 2) Test specimen 3) Ultrasonic couplant

<Detector>

Name of unit	Scope of delivery
1 Small/Small diameter/High temperature/Middle/Large	1) Sensor unit 2) Signal cable (5m) 3) Mounting belt/wire 4) Silicone grease (100g)

OPTIONAL ITEMS

	Name	Specifications	Arrange-ment No.
1	Battery	Special type Li-ion battery (7.4V, 2500mAh) \times 2	TK373312P4
2	Power adapter	Special type power adapter, with power cable, 2m 90 to 264V AC, 50/60Hz · AC power adapter · Power connector conversion mode	TK7N6380P1 TK4J2637C1
3	Printer unit	To be mounted on top of converter Thermal serial dot system (8 \times 384 dot)	TK4J2634C1
4	Printer roll paper	Maker: SEIKO I SUPPLY Co. Ltd. Type: LP-251L Specifications: Thermal roll paper Width: 58mm \times ϕ 48mm, No core	TK7G7982C1
5	Silicone grease	Maker: Shin-Etsu Chemical Co., Ltd. Type: · For standard use G40M, 100g · For high temperature KS62M, 100g	TK7G7984C1 TK7G7983C1
6	Signal cable	Special type signal cable, 5m \times 2 Connector on both sides Red connector Blue connector · Middle type/Large type sensor: BNC connector on one side	TK4J2640C1 TK4J2640C2 TK7G7987C1
7	Extension signal cable	Special type coaxial cable with BNC connector · 10m \times 2 · 50m \times 2	TK468664C3 TK468664C4
8	Analog input/output cable	4-core cable, 1.5m, with connector	TK4J2639C1
9	Mounting belt /wire	· Small type/small diameter sensor: Plastic cloth belt · Large type sensor: Stainless wire Nominal diameter $\phi 200$ to $\phi 500$ mm $\phi 200$ to $\phi 1000$ mm $\phi 200$ to $\phi 2000$ mm $\phi 200$ to $\phi 3000$ mm $\phi 200$ to $\phi 6000$ mm · High-temperature sensor: Stainless steel belt	TK7G7979C1 TK7G7980C1 TK7G7980C2 TK7G7980C3 TK7G7980C4 TK7G7980C5 TK7G7981C1
10	Thickness gauge detector	Cable length: 0.8mm Measuring range: 0.8 to 80mm Accuracy: 20mm or less ± 0.1 mm 20mm or more $\pm 0.5\%$ of read	TK7N6385P1
11	Guide rail for high-temperature sensor	· Case material: SUS304 · Mounting bracket material: Aluminum alloy+SUS304	TK4C6164C1
12	SD memory card	Maker: Apacer Technology, Inc. Type: AP-ESD256TPSR Capacity: 256MB	TK7N6386C1
13	USB cable	Maker: Sunwa Supply Inc. Type: KU-AMB510 Specifications: Mini USB cable (1.0m)	TK7N6622C1

Conditions on straight pipe

(D: Nominal diameter of pipe)

Type	Length of upstream straight pipe	Length of downstream straight pipe
90° bend		
Tee		
Diffuser		
Contraction pipe		
Valve		
Pump		

Note) Source: Japan Electric Measuring Instruments Manufacturers' Association (JEMIS-032)

OUTLINE DIAGRAM (Unit:mm)

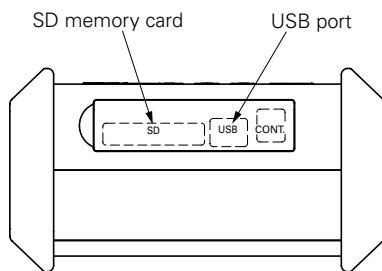
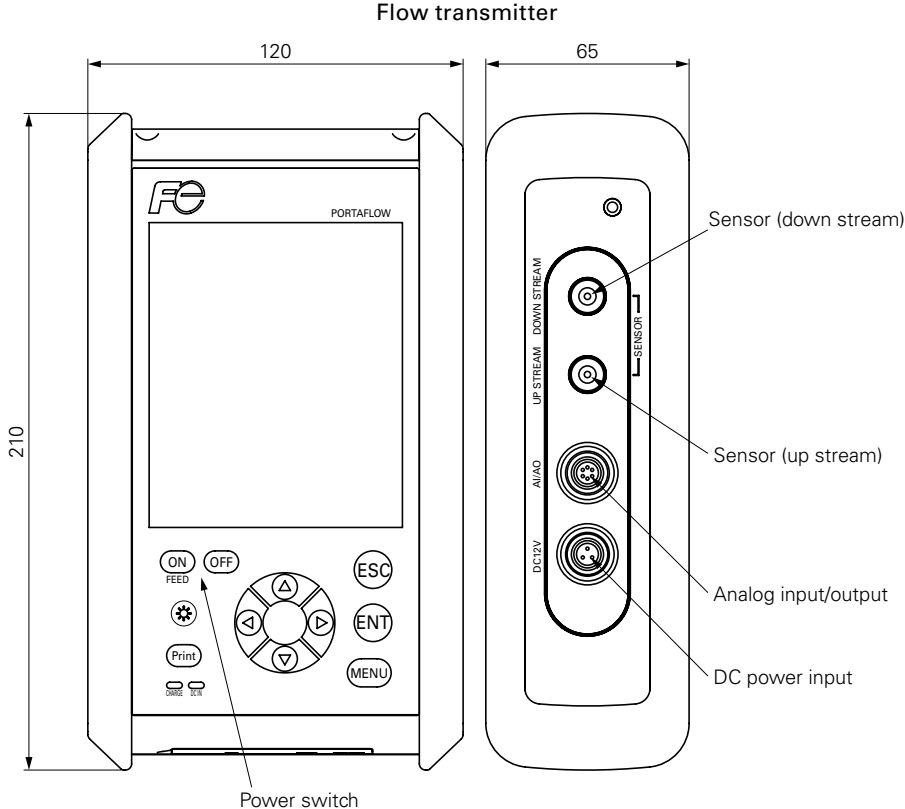

Weight : 1.0kg

OUTLINE DIAGRAM (Unit:mm)

Flow transmitter (with printer)

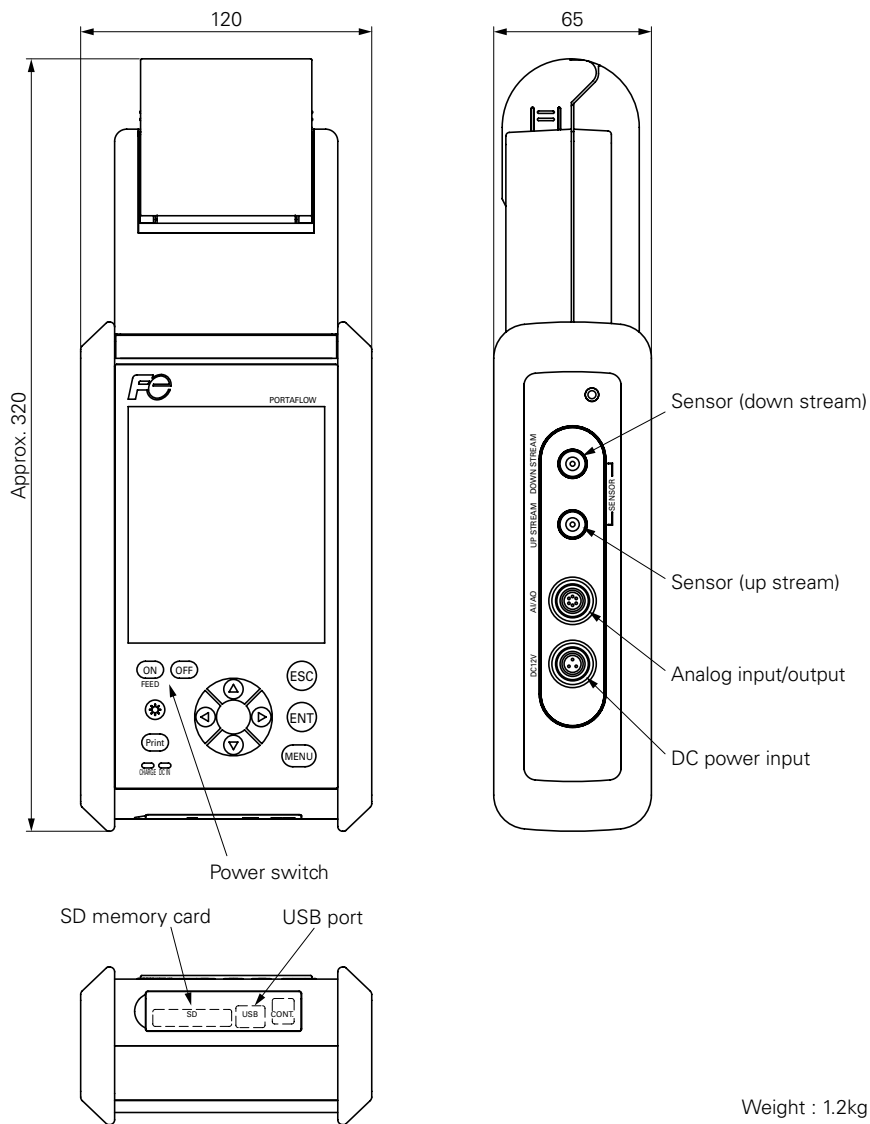

Weight : 1.2kg

OUTLINE DIAGRAM (Unit:mm)

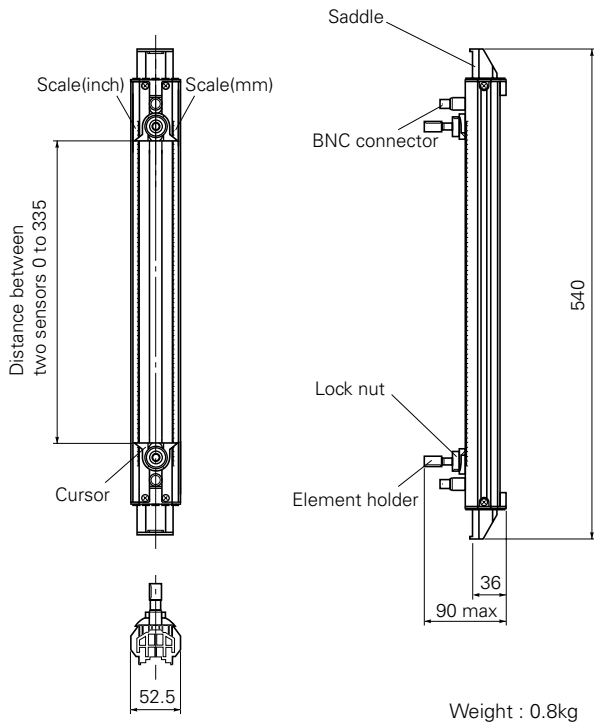

Detector FLD12 (Small sensor)

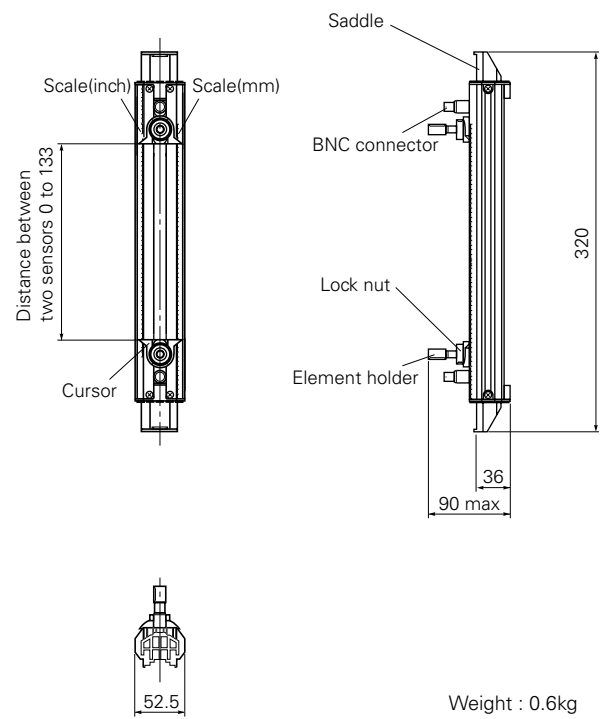

Detector FLD22 (Small diameter sensor)

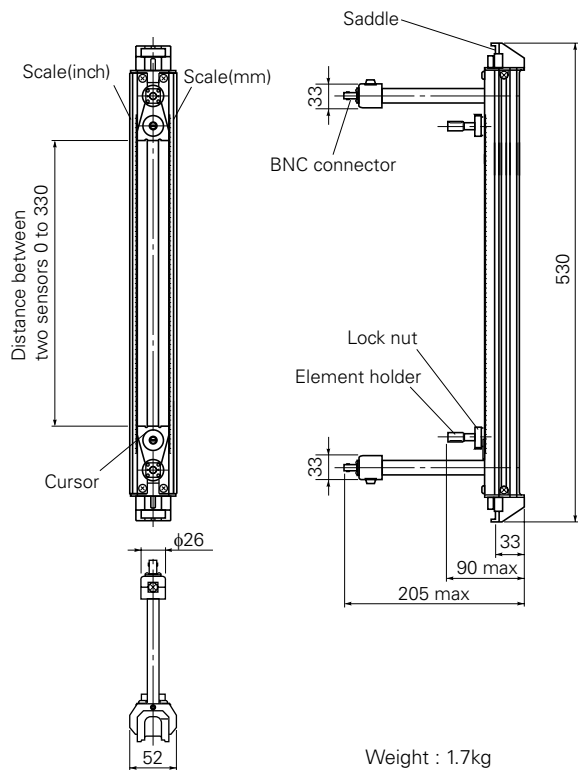

Detector FLD32 (High-temperature sensor)

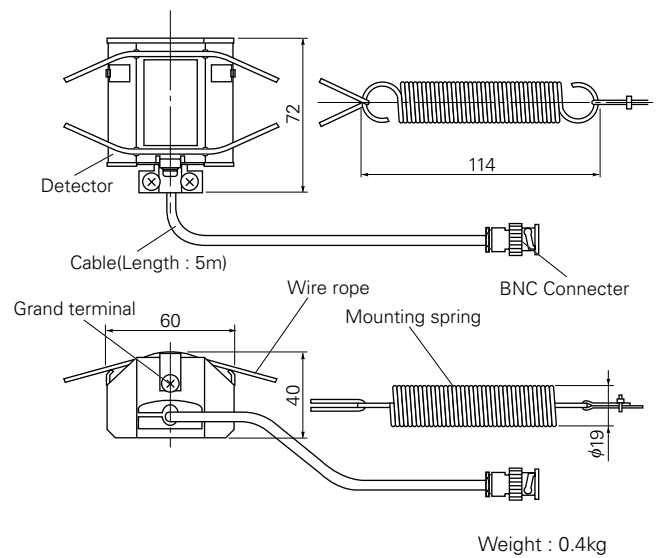

Detector FLD41 (Middle sensor)

OUTLINE DIAGRAM (Unit:mm)

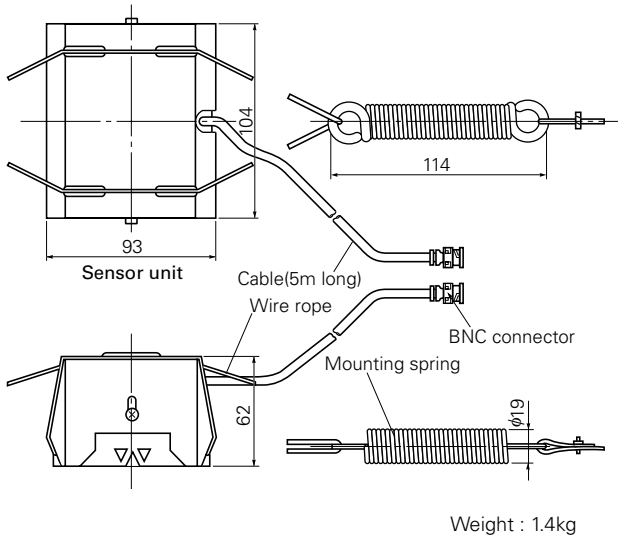

Detector FLD51 (Large sensor)

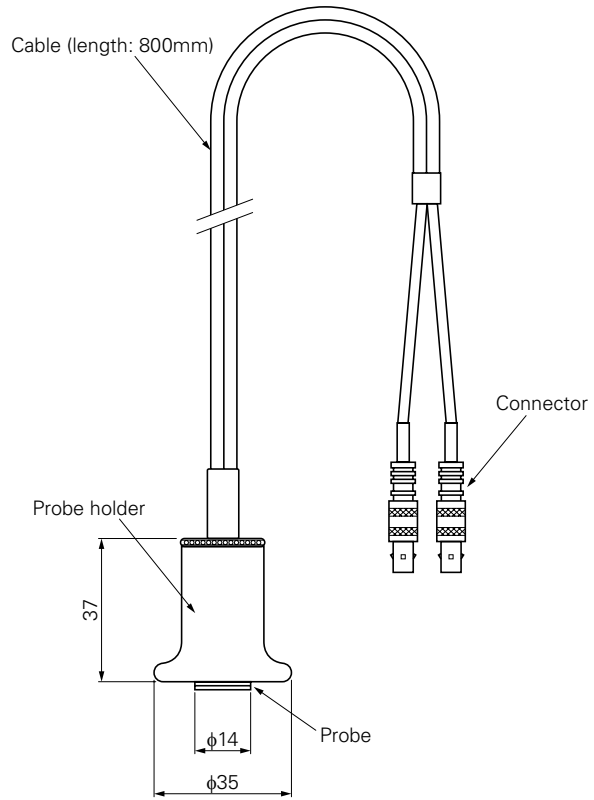

Ultrasonic thickness gauge

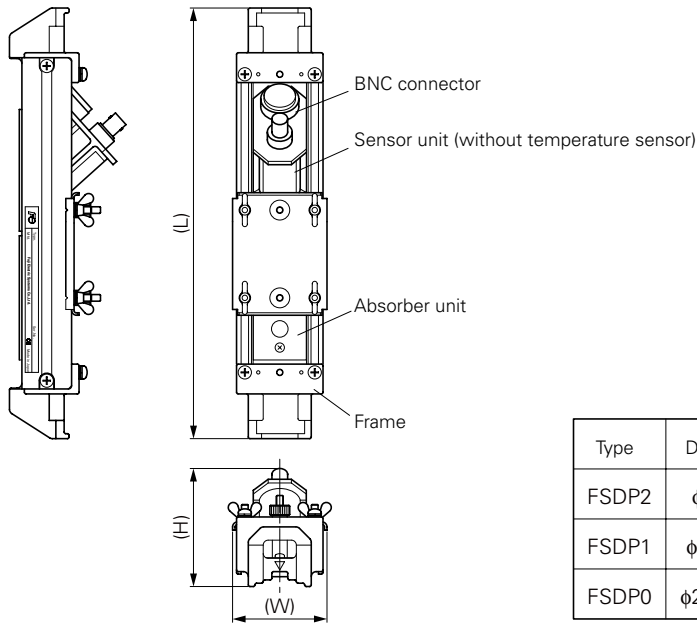

Detector FSD

Type	Diameter (mm)	L	H	W	Weight Approx. (kg)
FSDP2	φ40 to φ200	260	70	57	1.7
FSDP1	φ100 to φ400	260	72	57	1.7
FSDP0	φ200 to φ1000	350	90	85	4.5

⚠ Caution on Safety

*Before using this product, be sure to read its instruction manual in advance.

Fuji Electric Systems Co., Ltd.

**Sales Div. III, International Sales Group
Global Business Group**

Gate City Ohsaki, East Tower, 11-2, Osaki 1-chome,
Shinagawa-ku, Tokyo 141-0032, Japan

<http://www.fesys.co.jp/eng>

Phone: 81-3-5435-7280, 7281 Fax: 81-3-5435-7425

<http://www.fic-net.jp/eng>