

**Gas mass flow sensors for:**

Automotive

Commercial vehicle engines

Large engines

made by systec  
**truckflow**





TFI4 multivariable sensor platform on aluminum venturi

Without the precise control of air and EGR flows it would not be possible for the engines of modern passenger car and commercial vehicles to fulfil the strict exhaust emission regulations Euro6 EPA10 ff in Europe and North America. The correct lambda controls and the safe operation of gas engines only works through reliable natural gas and air mass flow sensors. Knowing the exact mass flow rates is paramount for the SCR post treatment of exhaust gases.

The requirements of gas mass flow sensors regarding contamination, corrosion, intake conditions, pulsation, pressure and temperature are as manifold as the applications. systec Controls has been focusing exclusively on flow metering technology since 1994. In 2003 systec Controls started the delivery of Truckflow – flow metering solutions for the engine industry. Sensor solutions by systec Controls are used as series products for engines at companies such as Daimler, Liebherr, AGCO, and MAN. systec sensors measure air, EGR, exhaust gas and natural gas. Reference metering systems by systec Controls improve the accuracy and reliability of engine testing benches around the world and are deployed by companies like FEV, MAN, and Daimler.

## Simple ideas are often the best ideas

Truckflow applies the principle of differential pressure. Flow measurements according to the principle of differential pressure have been used in the industry since the 19th century. They provide a number of decisive benefits, which makes them particularly attractive for use with engines:

- > Resistant to contamination
- > Suitable for high temperatures and pressures

Systec Controls has managed to compensate for the typical restrictions of differential pressure measurements through its own research and development. Truckflow measurements are characterized by:

- > Insensitivity to pulsation
- > Low pressure loss
- > Accuracy throughout the measuring range
- > Low drift
- > Long-term stability up to 1,600,000 km or 25,000h

## Threefold competence

Flow measurements according to the principle of differential pressure basically consist of three parts:

- > The primary element such as venturis, nozzles or pitot tubes.
- > The sensor system consisting of differential pressure, absolute pressure and temperature sensors.
- > The analysis, which is either conducted by the engine control unit (ECU) or the TFI4 platform developed by systec.

The use with engines presents special challenges for all three parts of flow measurement only a few manufacturers know and can manage better than systec Controls.

## Primary elements

Optimal flow measurements are only possible with carefully designed primary elements. The requirements regarding primary elements should not be underestimated. In contrast to industrial primary elements completely different requirements and challenges occur with engines: Pulsation, contamination, unsteady operation, high dynamics requirements, reduced intake conditions, pressure loss, etc.

system Controls has more than a decade of experiences with the optimization of primary elements. We are happy to support you throughout the complete design process. We check the intake conditions, conduct CFD's, optimize pressure losses, take care of packaging, develop special designs and produce prototypes and series elements. We support you all the way from preliminary design to end of production.

## Sensors

Even though there is a plurality of sensors for differential pressure, absolute pressure and temperature available for use in the automotive industry, most of them are not suitable for precise flow metering. Measuring the absolute and differential pressure signal is particularly decisive for achieving perfect measuring performance with long-term stability.

system Controls produces sensors, whose zero stability and accuracy is 10 to 100 times better than that of many other sensors. As a result, system sensors can measure considerable wider ranges than other differential pres-

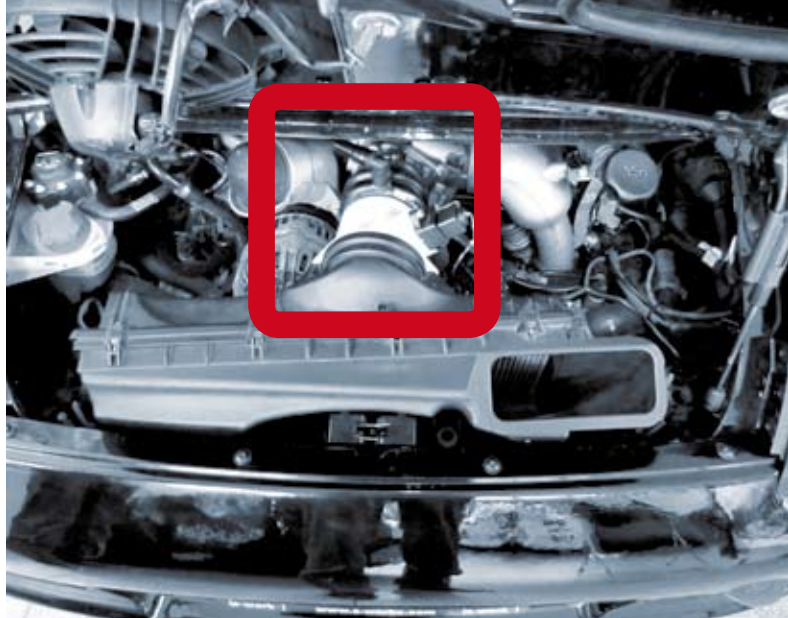

TFI4 with plastic venturi at Porsche GT3 racing engine

sure sensors. The dynamic measuring range of system sensors allows for pulsations to be recorded in applications close to the cylinder and their influence on flow metering can be compensated for. The result is perfect accuracy in every engine position.

## Analysis

The sensor signals are analyzed and the calculations are made in accordance with ISO 5167.

This may be conducted within the engine control unit in case of simple applications with low pulsations. system Controls can also support you in the implementation, the analysis of test bench runs and the optimization of engine maps in the engine control unit.

In applications applications close to the cylinder with a high degree of pulsations it is not suitable to have the analysis performed in the engine control unit. With TFI4 system Controls has designed a fully digital electronic analysis system, which provides perfect measuring values without the need for any engine map optimization. This is achieved by ultra-high sampling rates and complex analysis and filter algorithms.

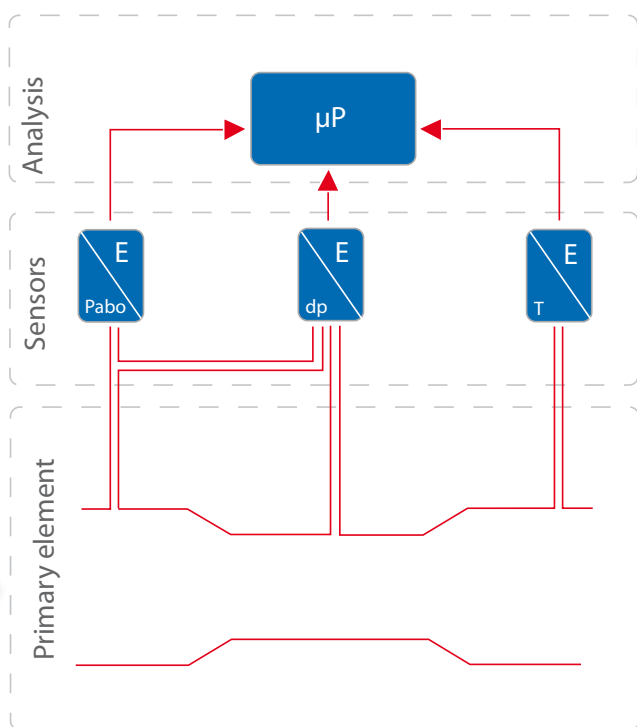



Sooting test with coated Truckflow pitot tube



High-temperature non-stick coating on stainless steel pitot tube

## Truckflow primary elements

The function and design of classical primary elements such as orifice plates, venturis and nozzles are described in standard ISO 5167. It also includes information on accuracies and correct deployment.

ISO 5167 is not sufficient in the automotive field, though. The standard does not document the special requirements in the automotive field: Transient operation with strong pulsations, smaller designs and shorter intake lengths, non-round pipe geometries, low pressure loss designs such as pitot tubes, special coatings and strategies when used in contaminated media, etc.

system Controls is in masterly control of the deployment and optimization of primary elements. We know the benefits and drawbacks of orifice plates, pitot tubes, venturis and nozzles. We have a wealth of experiences with non-standard-compliant designs and know how to achieve optimum results even with small available spaces and short intake lengths. We optimize volumes and line lengths to prevent the useful signals from being disturbed by pulsations and waves. We make sure that pressure losses are kept low or can even be reduced. We are aware of the influence of condensation and particles and have developed strategies for long-term stable measurements. We know the positions of engines at which measuring will cause problems and we know where the application will work optimally in no time at all. It is up to you to decide which of our consulting services you want to use for how long – we make sure that you will reach your objectives much quicker if you choose us as your consultant.



Series venturi for air after intercooler with systec TF14

Truckflow pitot tube for air before turbocharger made of aluminum

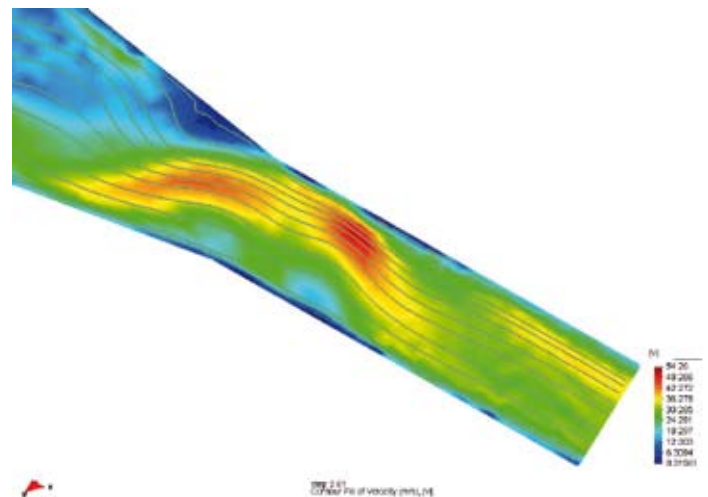

CFD optimization with shorter intake routes

In engine-related applications such as air after intercooler or EGR the use of venturis or special nozzles has proven to be advantageous. Truckflow pitot tubes or combinations of nozzles and pitot tubes are often used at measuring positions with low pulsations, such as air before turbocharger or before intercooler.

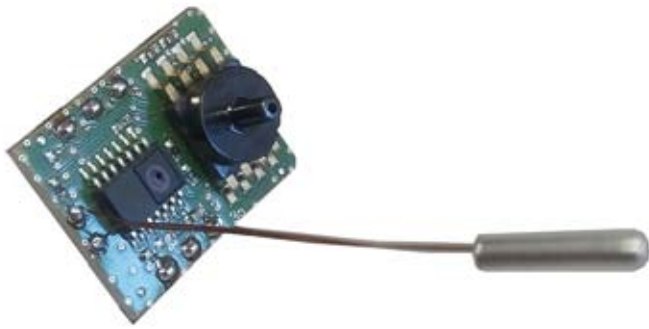

TFI4 multivariable sensor platform



TFI4 flange version venturi after environmental testing

## TFI4 – more than 20 years of development on just under 7cm<sup>2</sup>

The TFI4 sensor platform has been optimized completely for automotive use. Ultrafast and finely calibrated sensors provide the highest measuring accuracy at the engine. With sampling rates of more than 4 kHz TFI4 manages to separate pressure pulsations from flow pulsations, thus achieving accuracies in applications close to the cylinder, that could only be achieved with test benches technology up to now. As a CAN sensor TFI4 not only provides a perfectly processed flow rate signal but also the current pressure and temperature within the pipe as well as comprehensive OBD data. State-of-the-art coatings provide for the sensor's high resistance against chemical attacks.

The TFI4 sensor platform is available as a single-flange sensor for venturis and nozzles, as a hose sensor for high-temperature applications and as a compact pitot tube for insertion into a pipe.

## Pitot tubes with snap-in sensors

Pitot tubes with integrated dp sensors are an inexpensive alternative to applications with low requirements regarding measuring range, pulsation stability and accuracy. These flow meters are robust and long-term stable and thus perform their task throughout the complete life of commercial vehicles.



TFI4 as flange version for venturis



TFI4 as hose version for high-temperature applications



TFI4 as a compact pitot tube for insertion into a line



Truckflow pitot tube with snap-in dp sensor

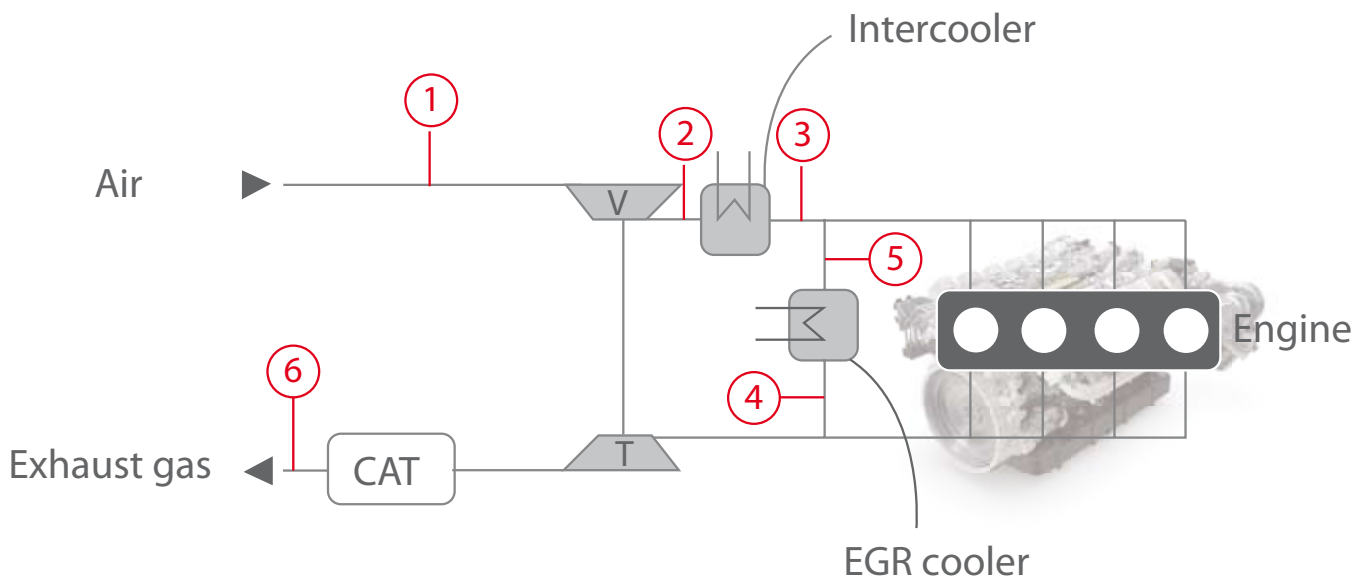

## Where do you have to measure?

The potential deployments of Truckflow gas mass flow measurements are just as varied as the engine and control concepts. Regardless of whether you want to measure air before or after the compressor, before or after the intercooler, at a two-stage turbocharger, cold or hot EGR, exhaust gas streams or even natural gas in your bi-fuel engine – find your solution together with us.

### 1. Air before turbocharger

At this measuring position both Truckflow pitot tubes and venturis with TFI4 analysis can be used. The calibration of the flow measurement depends on the inlet pipes, i.e. this measuring position is ideal if there is hardly any variance in the air ducting.



Truckflow pitot tube for air before turbocharger made of plastic with snap-in dp transducer

### 2. Air before intercooler

This is a particular favorable measuring position as the intercooler reduces pulsations and the pressure changes caused by the turbocharger leads to lower measurement spread and consequently to a larger measuring range. This allows extremely high accuracies to be achieved! Heat management defines whether a directly flanged version or a hose version of TFI4 will be used. The available space and the engine parameters determine the selection of the primary element (venturi, nozzle, pitot tube, special designs).

### 3. Air after intercooler

Due to the low temperatures directly flanged TFI4 models may be used at this position in most cases. This saves space and extra installation efforts. The TFI4 analysis (patent pending) masters the massive pulsations occurring within the direct vicinity of the engine. An adaptive filtering concept provides stable air mass flow values AND high dynamics with perfect accuracy.

### 4./5. Hot and cold EGR/AGR

In this context, we focus primarily on the design of the primary element. We support you with regard to problems relating to condensation and particles. Our experiences with state-of-the-art coatings improve the sensors' medium compatibility and reduce the sticking of particles on the primary element. Owing to the superior sensor technology in TFI4, solutions by systec have lower pressure losses than conventional solutions. This is helpful for increasing the EGR rate.

### 6. Exhaust gas volume measurement

Exhaust gas measuring is used e.g. in controlling the Ad-Blue injection at the SCR catalytic converter. Owing to the high temperatures the use of separate TFI4 hose sensors is the ideal solution in this case. Deployment after the particle filter is favorable, as the primary element is not contaminated further afterwards.

### 7. Other measuring positions

A plurality of other potential deployments is available, such as natural gas, biogas, air in multiple-stage charging, etc. Please contact us, we will be happy to consult you.

# Technical Specification

Classical primary elements	Pitot tubes	TFI4 sensor platform	Sensors
			
<b>Types:</b> <ul style="list-style-type: none"> <li>&gt; Venturis</li> <li>&gt; Nozzles</li> <li>&gt; Special designs and combinations</li> </ul>	<b>Types:</b> <ul style="list-style-type: none"> <li>&gt; Single-point</li> <li>&gt; Multi-point</li> <li>&gt; Combination of venturi and sensor</li> </ul>	<b>Sensors:</b> <ul style="list-style-type: none"> <li>&gt; dp</li> <li>&gt; pabs</li> <li>&gt; T on board</li> </ul>	<b>Sensors:</b> <ul style="list-style-type: none"> <li>&gt; dp sensors</li> <li>&gt; p sensors</li> <li>&gt; T sensors</li> <li>&gt; Combined sensors (p&amp;T)</li> </ul>
<b>Material:</b> <ul style="list-style-type: none"> <li>&gt; Aluminum</li> <li>&gt; Plastic</li> <li>&gt; Steel</li> <li>&gt; Stainless steel</li> </ul> <b>Coatings:</b> <ul style="list-style-type: none"> <li>&gt; Corrosion protection</li> <li>&gt; Non-stick coating</li> </ul>	<b>Material:</b> <ul style="list-style-type: none"> <li>&gt; Aluminum</li> <li>&gt; Plastic</li> <li>&gt; Stainless steel</li> </ul> <b>Coatings:</b> <ul style="list-style-type: none"> <li>&gt; Corrosion protection</li> <li>&gt; Non-stick coatings</li> </ul>	<b>Communication:</b> <ul style="list-style-type: none"> <li>&gt; CAN-Bus 2.0 B 250 kBit / 500 kBit / 1 MBit</li> </ul> <b>Electrical connection:</b> <p>Tyco HDSCS-6 (others upon request)</p>	<b>Communication:</b> <ul style="list-style-type: none"> <li>&gt; CAN-Bus</li> <li>&gt; 0-5VDC analogue</li> <li>&gt; PWM</li> </ul> <b>Electrical connection:</b> <p>Tyco HDSCS-6, others</p>
<b>Diameter:</b> <p>Min: 8 mm Max: arbitrary</p>	<b>Diameter:</b> <p>Min: 25 mm Max: arbitrary</p>	<b>Accuracy:</b> <ul style="list-style-type: none"> <li>&gt; 1% new</li> <li>&gt; better than 2% throughout lifetime</li> </ul>	<b>Accuracy:</b> <p>Depending on type</p>
<b>Pressure range (absolute):</b> <p>0 bar (vacuum) to &gt; 100 bars</p>	<b>Pressure range (absolute):</b> <p>0 bar (vacuum) to &gt; 100 bars</p>	<b>Pressure range:</b> <p>0.4bars abs or 0.7bars abs (others upon request)</p>	<b>Measuring range:</b> <p>Depending on type</p>
<b>Temperature range:</b> <p>- 40 to over 500 °C</p>	<b>Temperature range:</b> <p>- 40 to over 500 °C</p>	<b>Flow rate calculation:</b> <p>in accordance with EN IS 5167</p>	<b>Calculations:</b> <p>within the ECU</p>
<b>Sensor interfaces:</b> <ul style="list-style-type: none"> <li>&gt; Direct mounting (flanged)</li> <li>&gt; Split installation (hoses/pipes)</li> </ul>	<b>Sensor interfaces:</b> <ul style="list-style-type: none"> <li>&gt; Snap-in dp transducer</li> <li>&gt; Compact design with TFI4 electronic</li> <li>&gt; Hose connectors for separate dp transducer</li> </ul>	<b>Interface:</b> <ul style="list-style-type: none"> <li>&gt; Flange</li> <li>&gt; Hose connectors</li> <li>&gt; Compact version with pitot tube</li> </ul>	<b>Interface:</b> <ul style="list-style-type: none"> <li>&gt; Snap-in</li> <li>&gt; Flange</li> <li>&gt; O ring</li> <li>&gt; Hoses</li> <li>&gt; Pipes</li> </ul>
<b>Measuring range:</b> <ul style="list-style-type: none"> <li>&gt; Ca. 1:10 on low-pressure side</li> <li>&gt; Ca. 1:20 on high-pressure side</li> </ul>	<b>Measuring range:</b> <ul style="list-style-type: none"> <li>&gt; Ca. 1:7 on low-pressure side</li> <li>&gt; Ca. 1:15 on high-pressure side</li> </ul>	<b>Measuring range:</b> <ul style="list-style-type: none"> <li>&gt; Ca. 1:10 on low-pressure side</li> <li>&gt; Ca. 1:20 on high-pressure side</li> </ul>	<b>Measuring range:</b> <ul style="list-style-type: none"> <li>&gt; Depending on type</li> <li>&gt; typically 1:4</li> </ul>
<b>Media:</b> <ul style="list-style-type: none"> <li>&gt; Air</li> <li>&gt; Exhaust gas</li> <li>&gt; EGR/AGR</li> <li>&gt; Biogas</li> <li>&gt; Natural gas</li> </ul>	<b>Media:</b> <ul style="list-style-type: none"> <li>&gt; Air</li> <li>&gt; Exhaust gas</li> <li>&gt; EGR/AGR</li> <li>&gt; Biogas</li> <li>&gt; Natural gas</li> </ul>	<b>Media:</b> <ul style="list-style-type: none"> <li>&gt; Air</li> <li>&gt; Exhaust gas</li> <li>&gt; EGR/AGR</li> <li>&gt; Biogas</li> <li>&gt; Natural gas</li> </ul>	<b>Media:</b> <ul style="list-style-type: none"> <li>&gt; Air</li> <li>&gt; Exhaust gas</li> </ul>



### deltaflow for test stands

The deltaflow pitot tube is a high-precision flow metering system for steams, gases and liquids in pipes.



### deltaflowC for gas mass flow measuring

Ultrafast dp, p and T sensors and a high-performance processor, which can measure the mass flow of gases up to 4,000 times per second.



### deltawaveC

deltawaveC by systec Controls is the new universal clamp-on ultrasound flow meter for liquid media in full pipes.



The headquarters of the company systec Controls is located in Puchheim near Munich. Here we develop and produce our products in accordance with DIN EN ISO 9001. But innovation and product quality alone are not enough for us. We have also submitted our systems for examination by independent institutions—and they have been clearly proven to be efficient and reliable.

By the way, we continue to be at your service even after your equipment has been installed. Our field service and customer service technicians will be happy to support you directly on-site, if requested. **systec Controls – the specialist in flow metering technology.**